

REV.	DESCRIPTION	DATE
A	New Drawing	2019/03/18

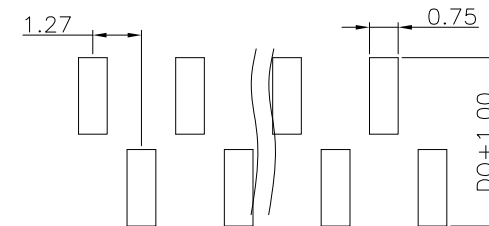

### P.C.B LAYOUT

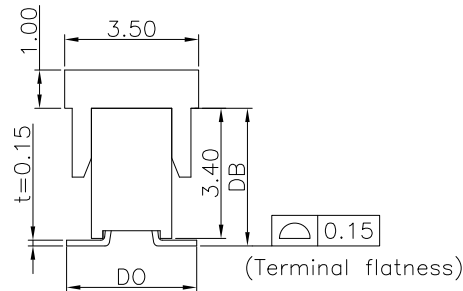
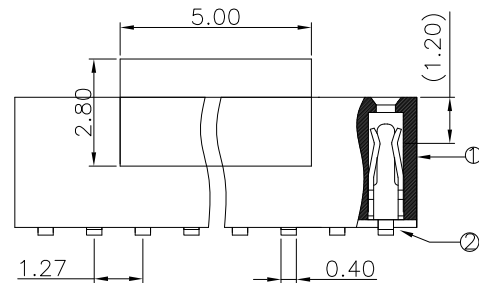
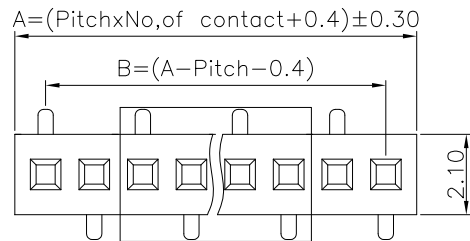
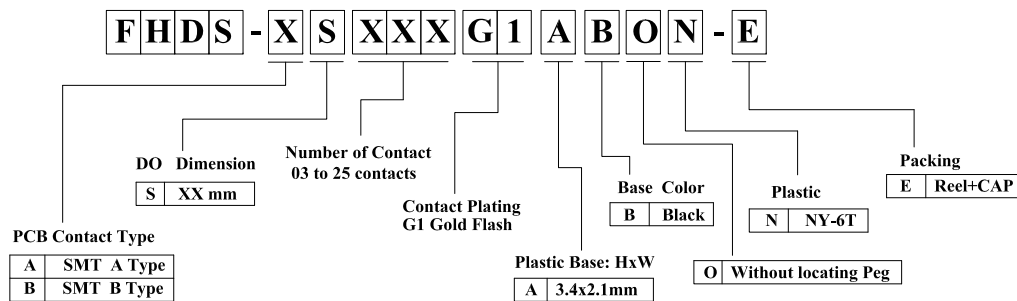

RoHS compliant

竣豪電子股份有限公司  
**Superior Tech Co., Ltd.**

General Tolerance		TITLE	Pitch 1.27mm Female Header SMT, Single Row	
X. ± 0.5		DRAWN	DATE	NO.
.X ± 0.3		Tom	03-18-19'	002
.XX ± 0.2		CHECK	DATE	PART NO.
.XXX ± 0.1		APPROVED	DATE	FHDS-XSXXXG1ABON-E
角度 ± 5°				CUSTOMER NO.

REV.	UNIT	SCALE	
A	mm	5:1	

(Q2-R03-01A) ST-R05-07