

REV.	DESCRIPTION	DATE
A	New Drawing	2008/06/27

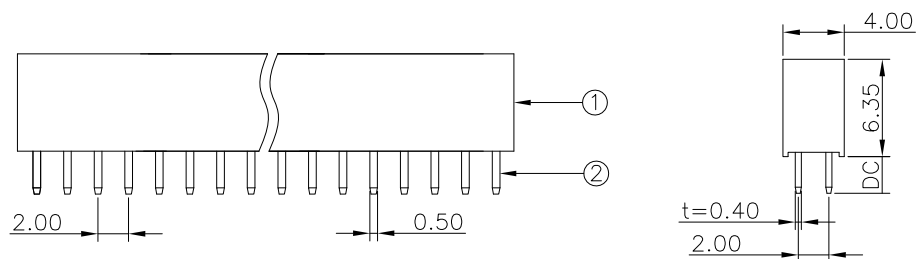

LTR	Part Name	Material	Description	QTY
1	Housing	NY-6T UL94V-0	260°C for 10 Seconds . Initial : 1000M Ohms Min. After Test : 500M Ohms Min.	1
2	Contact	Bronze C5191	Current Rating : 2.0A Initial : 20m Ohms Max. After Test : 40m Ohms Max.	XX

Normal Force : 60 Grams Average .
 Temperature Rating : -40°C ~ +125°C .
 Dielectric Withstanding Voltage : 1000V AC/Min .

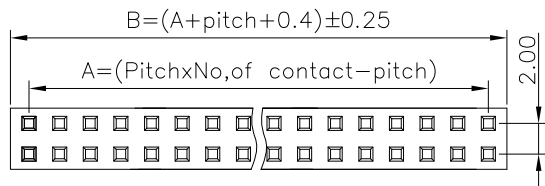
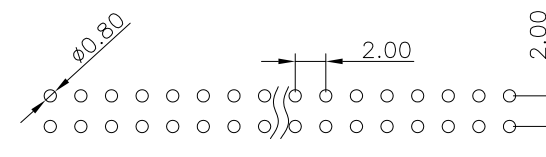

P.C.B LAYOUT

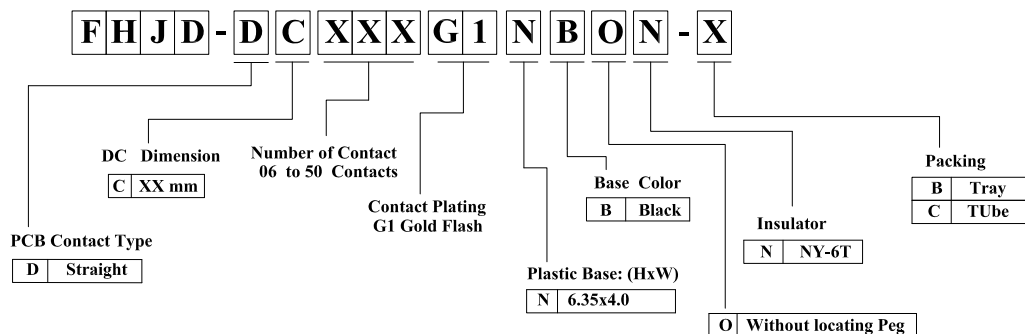

RoHS compliant

竣豪電子股份有限公司
Superior Tech Co., Ltd

General Tolerance		TITLE	Pitch 2.0mm Female Header H 6.3 DIP Type	
X. ± 0.5		DRAWN	DATE	NO.
.X ± 0.3		ZhaoXiaoLin	06-27-08'	002
.XX ± 0.2		CHECK	DATE	PART NO.
.XXX ± 0.1		XiaoPing	06-27-08'	FHJD-DCXXXG1NBON-X
角度 ± 5°		APPROVED	DATE	CUSTOMER NO.
		XiaoLin	06-27-08'	

REV.	UNIT	SCALE
A	mm	2:1

