

REV.	DESCRIPTION	DATE
A	New Drawing	2019/05/20

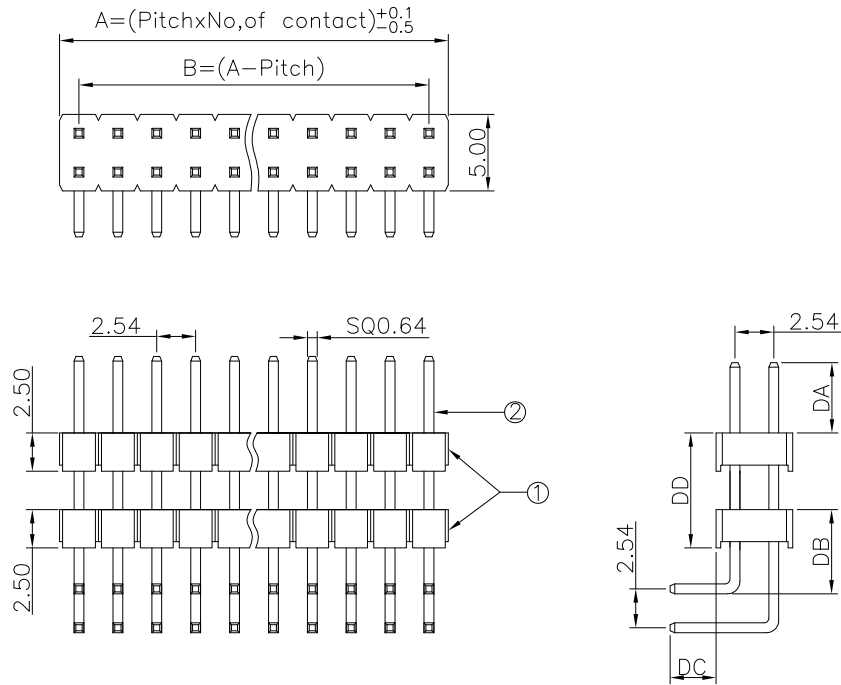

LTR	Part Name	Material	Description	QTY
1	Housing	Nylon UL94V-0	260°C for 10 Seconds . Initial : 1000M Ohms Min. After Test : 500M Ohms Min.	2
2	Contact	Brass	Current Rating : 3.0A Initial : 20m Ohms Max. After Test : 40m Ohms Max.	XX

Temperature Rating : -40°C ~ +125°C .
Dielectric Withstanding Voltage : 1000V AC/Min

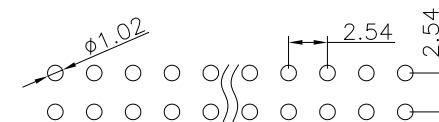

P.C.B. LAYOUT

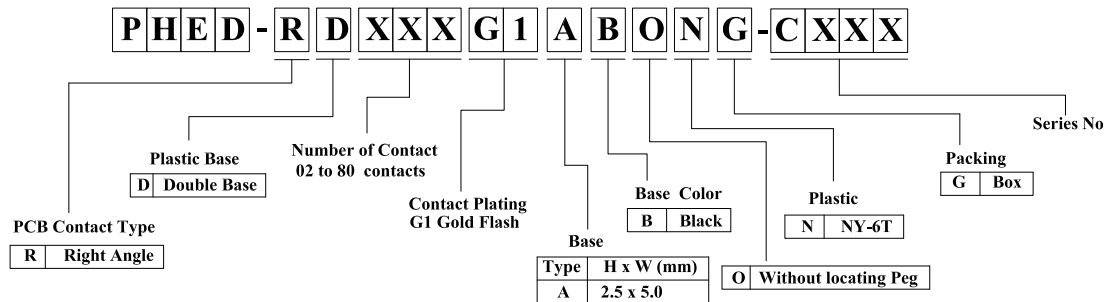

RoHS compliant

竣豪電子股份有限公司
Superior Tech Co., Ltd.

General Tolerance		TITLE	Pitch 2.54x2.54mm Pin Header Dual Row,90°	
X.	± 0.5	DRAWN	DATE	NO.
.X	± 0.3	Tom	05-20-19'	002
.XX	± 0.2	CHECK	DATE	PART NO.
.XXX	± 0.1	APPROVED	DATE	PHED-RDXXXG1ABONG-CXXX
角度	± 5°			CUSTOMER NO.

REV.	UNIT	SCALE
A	mm	1:1

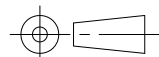

(Q2-R03-01A) ST-R05-07