

REV.	DESCRIPTION	DATE
A	New Drawing	2022/08/04

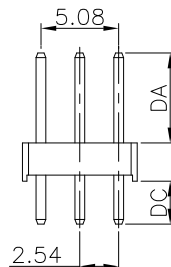

LTR	Part Name	Material	Description	QTY
1	Housing	Nylon UL94V-0	260°C for 10 Seconds . Initial : 1000M Ohms Min. After Test : 500M Ohms Min.	1
2	Contact	Brass	Current Rating : 3.0A Initial : 20m Ohms Max. After Test : 40m Ohms Max.	XXX

Temperature Rating : -40°C ~ +125°C .  
Dielectric Withstanding Voltage : 1000V AC/Min

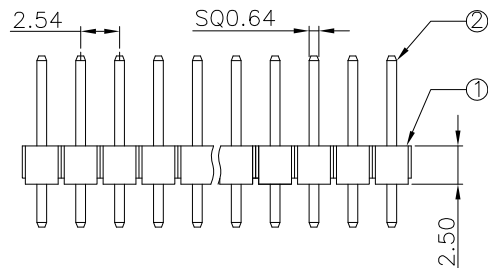
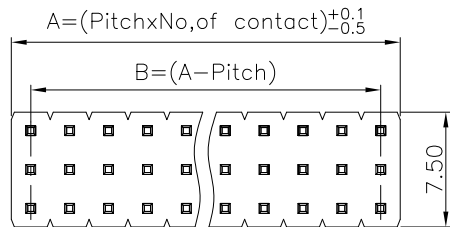
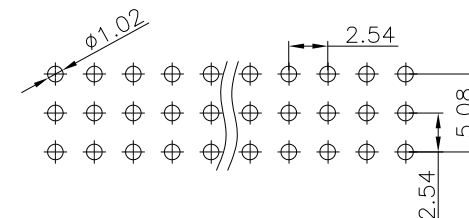

P.C.B LAYOUT

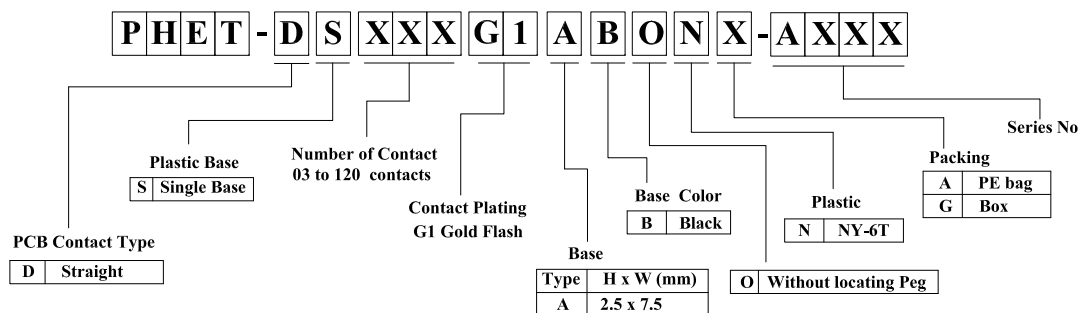

RoHS compliant

竣豪電子股份有限公司  
**Superior Tech Co., Ltd.**

General Tolerance		TITLE	Pitch 2.54x2.54x2.54mm Pin Header Straight Treble Rows	
X. ± 0.5		DRAWN	DATE	NO.
.X ± 0.3		Jacky	08-04-22'	002
.XX ± 0.2		CHECK	DATE	PART NO.
.XXX ± 0.1		Tom	08-04-22'	PHET-DSXXXG1ABONX-AXXX
角度	± 5°	APPROVED	DATE	CUSTOMER NO.
		Tom	08-04-22'	

REV.	UNIT	SCALE	
A	mm	1:1	

(Q2-R03-01A) ST-R05-07