

REV.	DESCRIPTION	DATE
A	New Drawing	2023/03/14

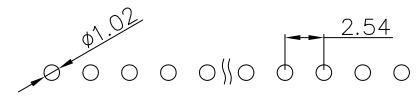
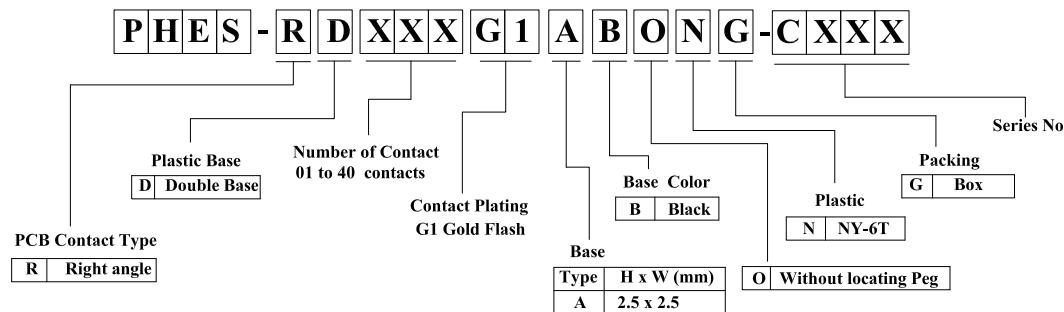
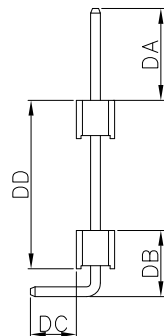
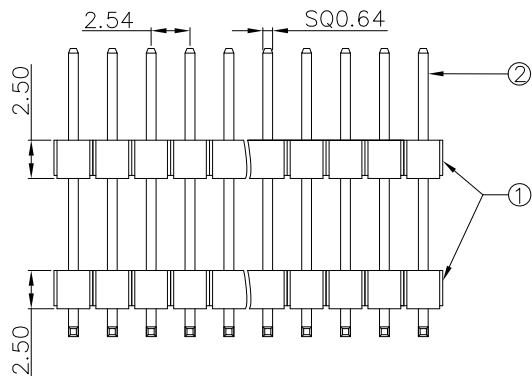
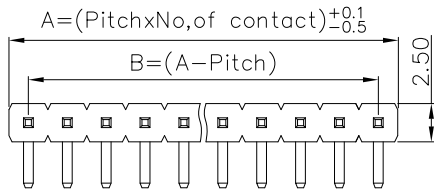

P.C.B LAYOUT

RoHS compliant

竣豪電子股份有限公司
Superior Tech Co., Ltd.

General Tolerance		TITLE		2.54Pin Header Single Row.	
X. ± 0.5		DRAWN		DATE	NO.
.X ± 0.3		Jacky		03-14-23'	002
.XX ± 0.2		CHECK		DATE	PART NO.
.XXX ± 0.1		Tom		03-14-23'	P H E S - R D X X X G 1 A B O N G - C X X X
角度 ± 5°		APPROVED		DATE	CUSTOMER NO.
		Tom		03-14-23'	

REV.	UNIT	SCALE	
A	mm	2:1	