

| REV. | DESCRIPTION | DATE      |
|------|-------------|-----------|
| A0   | New Drawing | 2007/2/10 |

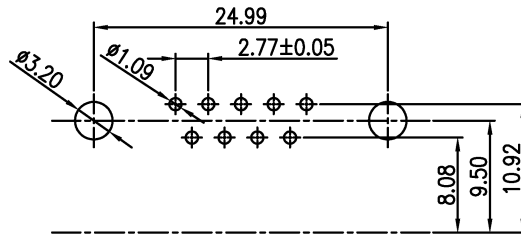

**P.C.B LAYOUT**

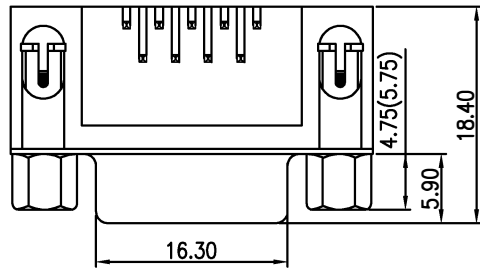
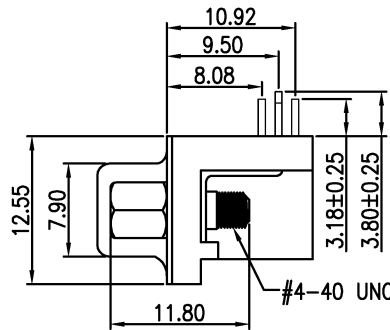
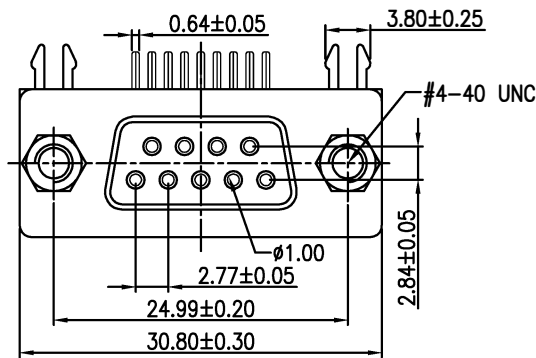

**MATERIAL:**

1. Insulator: PBT+30%Glass Fiber (UL94V-0)
2. Contact: Brass
3. Contact Plated: Gold Flash over Tin  
Or Gold Plated Or Tin Plated
4. Shell: Steel, Nickel Plated

**SPECIFICATION:**

1. Current Rating: 5 AMPS
2. Insulation Resistance: 5000MΩ MIN. At 500VDC
3. Dielectric Strength: 500V for One minute
4. Operation Temperature: -55°C ~ +105°C.

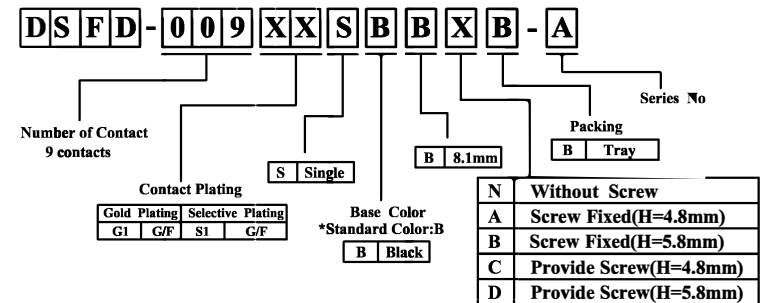

竣豪電子股份有限公司  
**Superior Tech Co., Ltd.**

General Tolerance

TITLE

D-SUB 9母 H8.1 90° 全系列

X. ± 0.5

DRAWN

DATE

DWG. NO.

.X ± 0.3

YangFeng

02-10-07'

DSM0019

.XX ± 0.2

CHECK

DATE

PART NO.

.XXX ± 0.1

Fuqianshan

02-10-07'

DSMD-009XXSBBXB-A

APPROVE

DATE

CUSTOMET NO.

角度

± 5°

YEH

02-10-07'

REV.

A0

UNIT

mm

SCALE

2:1

