

REV.	DESCRIPTION	DATE
A	New Drawing	2021/07/29

REMARKS:

- MATERIAL:
 - INSULATOR: THERMOPLASTIC UL 94V-0 RATED,COLOR: BLACK
 - CONTACT: COPPER ALLOY
 - SHELL: COPPER ALLOY
 - DUST CAP: THERMOPLASTIC UL94V-0,COLOR: BLACK
- PLATING:
 - CONTACT:

GOLD PLATED OVER NICKEL ON CONTACT AREA AND 100u" MIN. MATTED TIN OR GOLD PLATED OVER NICKEL ON SOLDER TAILS
 - SHELL:

SOLDERABLE NICKEL OR GOLD PLATED

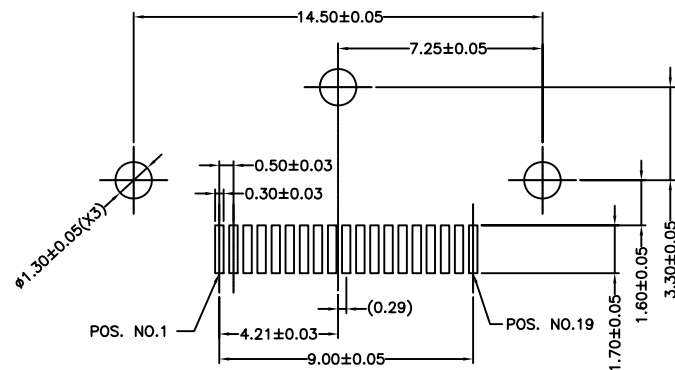
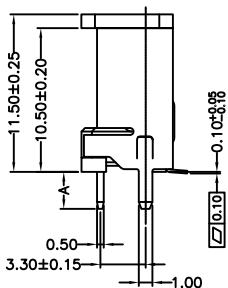
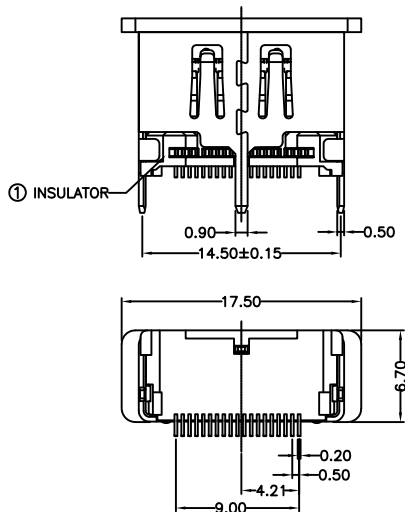
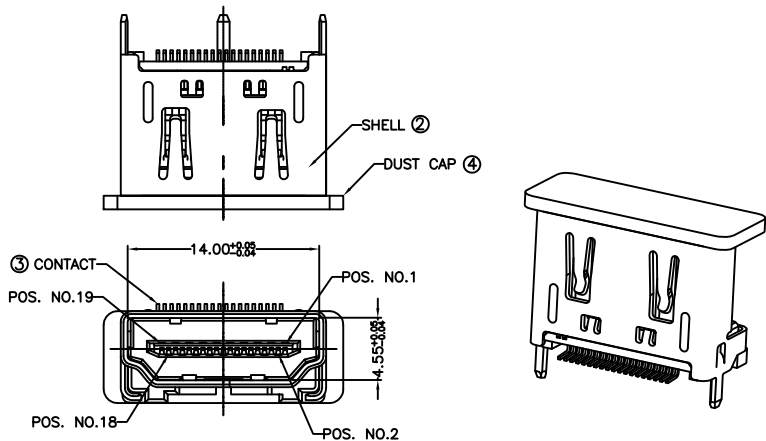

HDMI - S X 019 S C C O E - A27

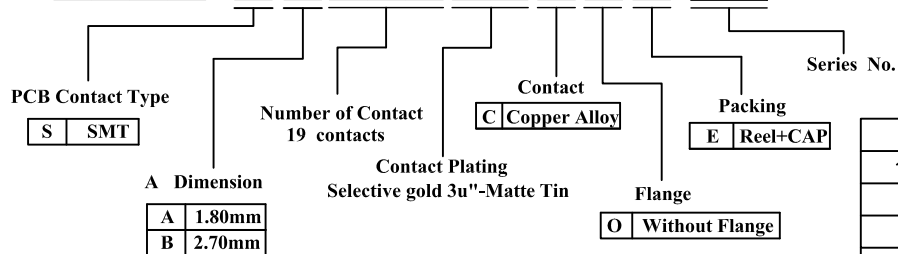

A Dimension

A	1.80mm
B	2.70mm

QTY'S	SPECIFICATION	SUPPLIER	PART	ITEM
1	THERMOPLASTIC	HAIQIONG	DUST CAP	4
19	COPPER ALLOY,T=0.20mm	YIHONG	CONTACT	3
1	COPPER ALLOY,T=0.50mm	YIHONG	SHELL	2
1	THERMOPLASTIC	HAIQIONG	INSULATOR	1

ROHS Compliant

竣豪電子股份有限公司
Superior Tech Co., Ltd.

General Tolerance	TITLE	HDMI PH 0.5 SMT 19Pin		
X. ± 0.5	DRAWN	DATE	NO.	
.X ± 0.3	Jacky	07-29-21'	T082	
.XX ± 0.2	CHECK	DATE	PART NO.	
.XXX ± 0.1	Tom	07-29-21'	HDMI-SX019SCCOE-A27	
角度 ± 5°	APPROVED	DATE	CUSTOMER NO.	
	Joe	07-29-21'		

REV. A	UNIT mm	SCALE 1:1	
--------	---------	-----------	--