

REV.	DESCRIPTION	DATE
A	New Drawing	2020/5/20

NOTES:
SPECIFICATION:

- CURRENT RATING: 3.0A MAX
- VOLTAGE: 100 VAC
- TEMPERATURE RANGE: -30 °C ~ 85 °C
- CONTACT RESISTANCE: 40 MILLIONHM MAX
- INSULATION RESISTANCE: 100 MEGOHMS MIN.
- INSERTION FORCE : 5N~20N
- UNMATING FORCE: 8N~20N
- DURABILITY: 10,000 CYCLES
- WATER PROOFNESS: THIS PRODUCT IS BASED ON IPX7.

PIN ASSIGNMENT:

PIN NO	A1&B12	A4&B9	A5	A5	A9&B4	A12&B1
SIGNAL NAME	GND	VBUS	CC1	CC2	VBUS	GND
PCB PAD NO.	C1	C2	C3	C4	C5	C6

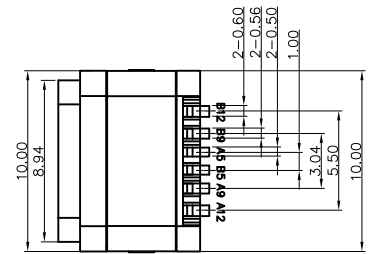
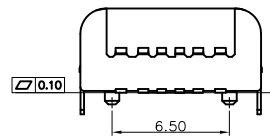
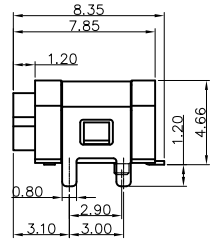
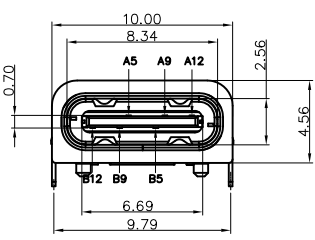
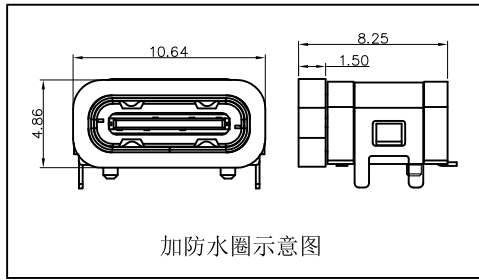
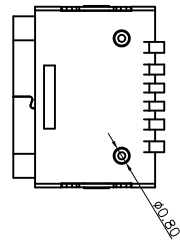
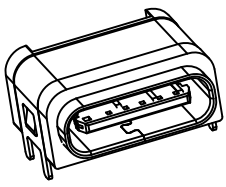

6	防水圈	硅胶	BLACK	1PCS
5	SHELL	STAINLESS STEEL	NI Plated	1PCS
4	SHIELDING PLATE	STAINLESS STEEL	NI Plated	1PCS
3	CONTACT	COPPER ALLOY	TIN/Au/Ni Plated	1SET
2	SHELL HOUSING	HIGH TEMPERATURE PLASTIC	BLACK	1PCS
1	HOUSING	HIGH TEMPERATURE PLASTIC	BLACK	1PCS
NO.	DESCRIPTION	MATERIAL	REMARKS	QTY

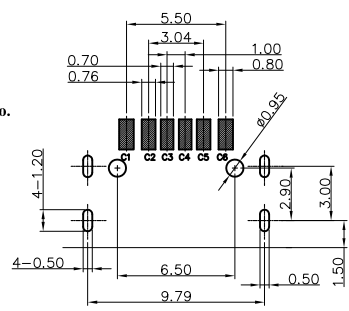
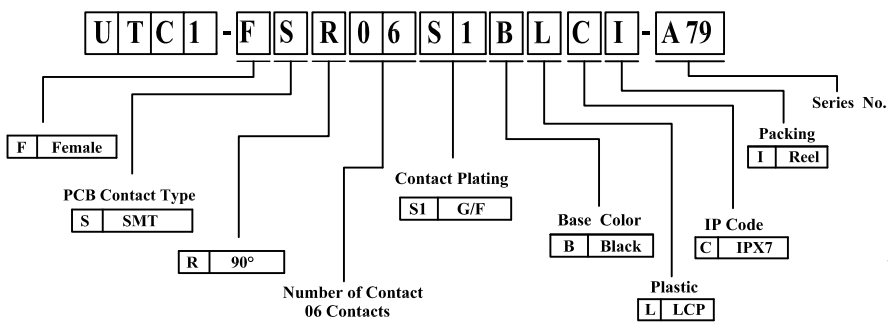

RECOMMENDED P.C.B. LAYOUT
TOLERANCE UNSPECIFIED ±0.05mm

RoHS compliant

竣豪電子股份有限公司
Superior Tech Co., Ltd.

General Tolerance	TITLE	USB Type C Female SMT 90° 6P 板上防水型	
X. ± 0.5	DRAWN	DATE	NO.
.X ± 0.3	Annie	05-20-20'	S054
.XX ± 0.2	CHECK	DATE	PART NO.
.XXX ± 0.1	Annie	05-20-20'	UTC1-FSR06S1BLCI-A79
角度 ± 5°	APPROVED	DATE	CUSTOMER NO.
	Tom	05-20-20'	

REV.	UNIT	SCALE	
A	mm	1:1	