

REV.	DESCRIPTION	DATE
A	New Drawing	2020/5/26

NOTE:

- MATERIAL SPECIFICATION:
 - HOUSING: HIGH TEMPERATURE RESISTANT PLASTIC, UL94 V-0.
 - CONTACTS: COPPER ALLOY
 - MID PLATE: STAINLESS STEEL
 - FRONT SHELL: STAINLESS STEEL
 - EMI PLATE: STAINLESS STEEL
- PLATING SPECIFICATION:
 - CONTACTS:
 - Ni 50u" MIN. UNDER PLATED OVER ALL.
 - Au PLATED ON THE FUNCTIONAL AREA OF CONTACT.
 - (GOLD PLATING THICKNESS FOLLOW THE P/N)
 - PLATING SPECIFICATIONS OF THE SOLDER AREA FOLLOW THE P/N
 - FRONT SHELL:
 - Ni 30u" MIN. UNDER PLATED OVER ALL.
 - MID PLATE & EMI PLATE:
 - CLEAR ONLY
- MECHANICAL PERFORMANCE,
 - INSERTION FORCE: 0.5~2.0kgf.
 - REMOVAL FORCE: 0.8kgf~2.0kgf.
 - DURABILITY: 10000 CYCLES.
- ELECTRICAL PERFORMANCE,
 - CURRENT RATING: 5.0A
VOLTAGE RATING: 5.0V
 - LLCR:
 - VBUS & GND PINS AND OTHER PINS: 40mΩ/PIN MAX.
 - SHIELD: 50mΩ/MAX.
 - LLCR MAX. CHANGE OF ALL PINS: 10mΩ.
 - INSULATION RESISTANCE: 100MΩ MIN
 - DIELECTRIC WITHSTAND VOLTAGE, AC 100V FOR 1 MINUTE.
- ENVIRONMENTAL PERFORMANCE:
 - OPERATING TEMPERATURE: -25°C~+85°C.
- IR REFLOW:
 - THE PEAK TEMPERATURE ON THE BOARD SHALL BE MAINTAINED FOR 10 SECONDS AT 260°C.

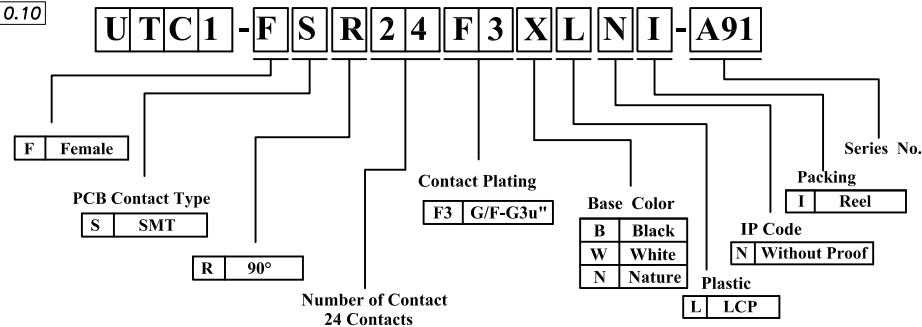
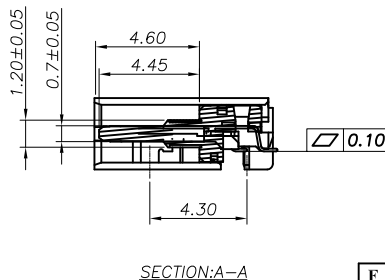
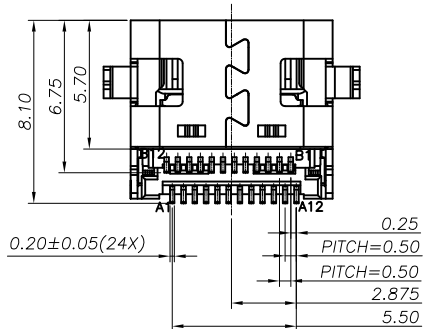
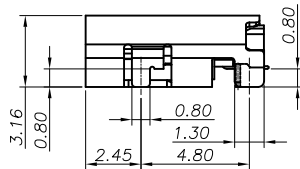
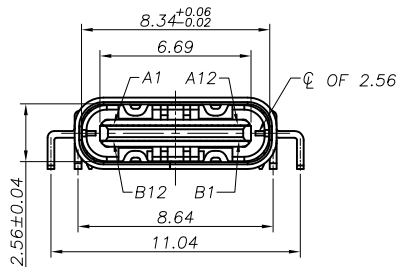
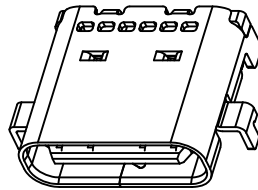
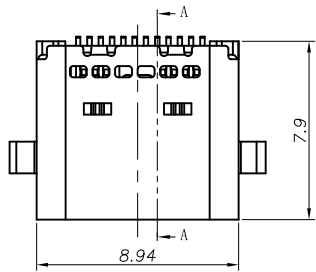

RoHS compliant

竣豪電子股份有限公司
Superior Tech Co., Ltd.

General Tolerance		TITLE	USB Type C Female SMT 90° 24P MID MOUNT 0.8	
X. ± 0.5		DRAWN	DATE	NO.
.X ± 0.3		Annie	05-26-20'	S054
.XX ± 0.2		CHECK	DATE	PART NO.
.XXX ± 0.1		Annie	05-26-20'	UTC1-FSR24F3XLNI-A91
REV.	UNIT	SCALE	APPROVED	DATE
A	mm	1:1	Tom	05-26-20'
			CUSTOMER NO.	1/3

REV.	DESCRIPTION	DATE
A	New Drawing	2020/5/26

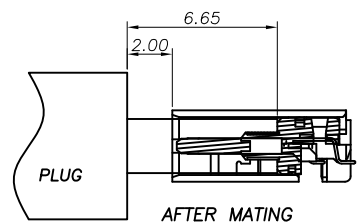

USB TYPE-C PIN ASSIGNMENTS

PIN NUMBER	SIGNAL NAME	PIN NUMBER	SIGNAL NAME
A1	GND	B12	GND
A2	SSTXp1	B11	SSRXp1
A3	SSTXn1	B10	SSRXn1
A4	VBUS	B9	VBUS
A5	CC1	B8	SBU2
A6	Dp1	B7	Dn2
A7	Dn1	B6	Dp2
A8	SBU1	B5	CC2
A9	VBUS	B4	VBUS
A10	SSRXn2	B3	SSTXn2
A11	SSRXp2	B2	SSTXp2
A12	GND	B1	GND

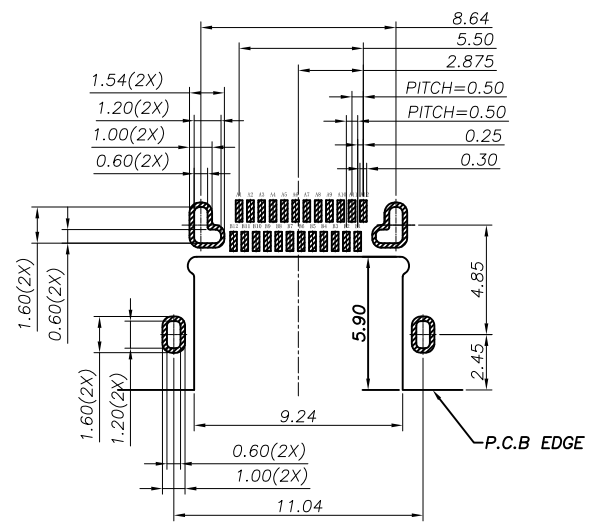

RECOMMENDED PCB LAYOUT(TOP VIEW)
THICKNESS 0.60MM;DEFAULT TOLERANCE:±0.05

RoHS compliant

竣豪電子股份有限公司 Superior Tech Co., Ltd.			General Tolerance		TITLE USB Type C Female SMT 90° 24P MID MOUNT 0.8		
			X. ± 0.5		DRAWN Annie		DATE 05-26-20'
		.X ± 0.3		CHECK Annie		DATE 05-26-20'	PART NO. UTC1-FSR24F3XLNI-A91
		.XX ± 0.2		APPROVED Tom		DATE 05-26-20'	CUSTOMER NO. 2/3
REV. A	UNIT mm	SCALE 1:1		.XXX ± 0.1	角度 ± 5°		

REV.	DESCRIPTION	DATE
A	New Drawing	2020/5/26

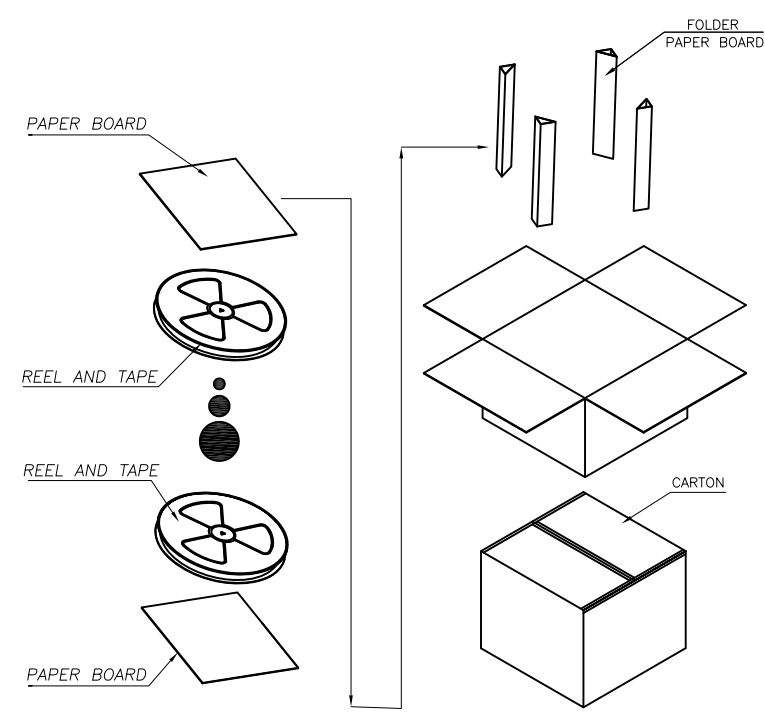
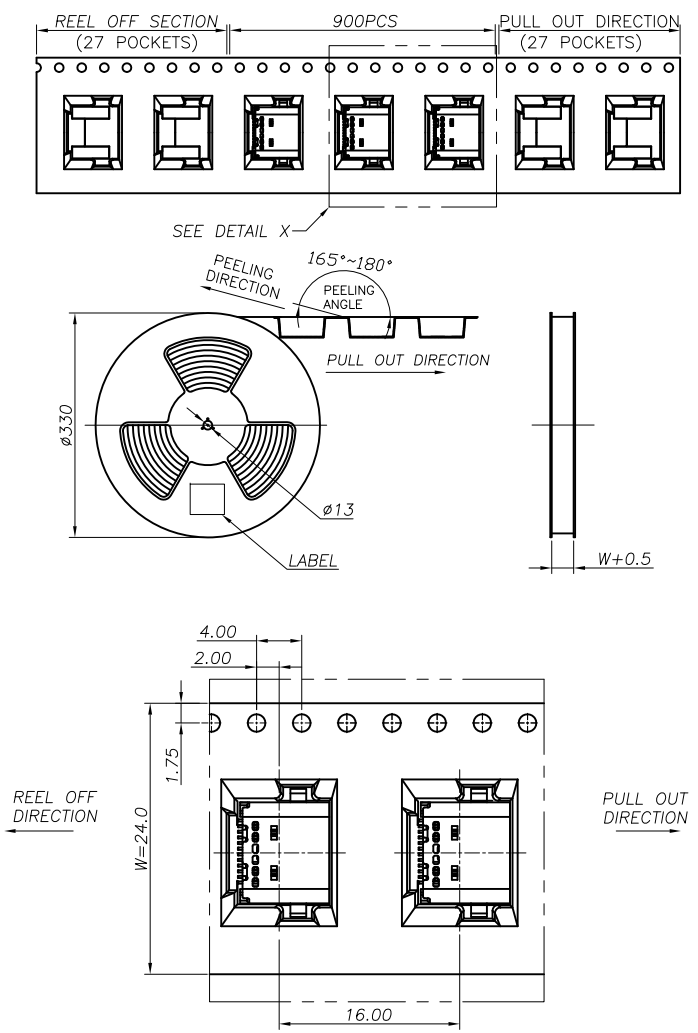

RoHS compliant

	REEL	CARTON
CONNECTOR (PCS)	900	9000

竣豪電子股份有限公司
Superior Tech Co., Ltd.

General Tolerance		TITLE		USB Type C Female SMT 90° 24P MID MOUNT 0.8 包裝圖	
X. ± 0.5		DRAWN	DATE	NO.	
.X ± 0.3		Annie	05-26-20'	S054	
.XX ± 0.2		CHECK	DATE	PART NO.	
.XXX ± 0.1		Annie	05-26-20'	UTC1-FSR24F3XLNI-A91	
角度 ± 5°		APPROVED	DATE	CUSTOMER NO.	
		Tom	05-26-20'	3/3	

REV.	UNIT	SCALE	
A	mm	1:1	