

REV.	DESCRIPTION	DATE
A	New Drawing	2019/10/07

NOTES:

- MATERIAL:
HOUSING: LCP ,UL 94-V0,COLOR:WHITE;
COVER: LCP ,UL 94-V0,COLOR:Black
CONTACT: COPPER ALLOY C5210;
LEG: COPPER ALLOY C5210;
- PLATING:
CONTACT: GOLD OR TIN PLATED ON NICKEL OVERALL.
LEG: TIN PLATED ON NICKEL OVERALL.
- RATING:
CURRENT RATING: 0.4A AC/DC
VOLTAGE RATING: 50V AC/DC
TEMPERATURE RANGE: -40~+105°C

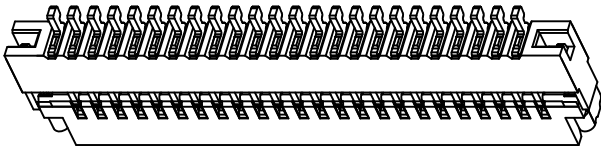

3D Drawing

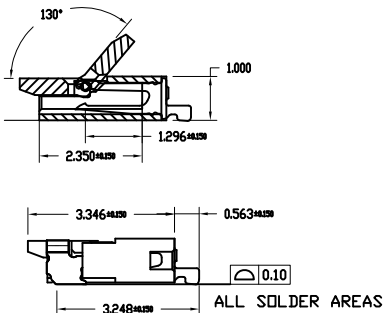
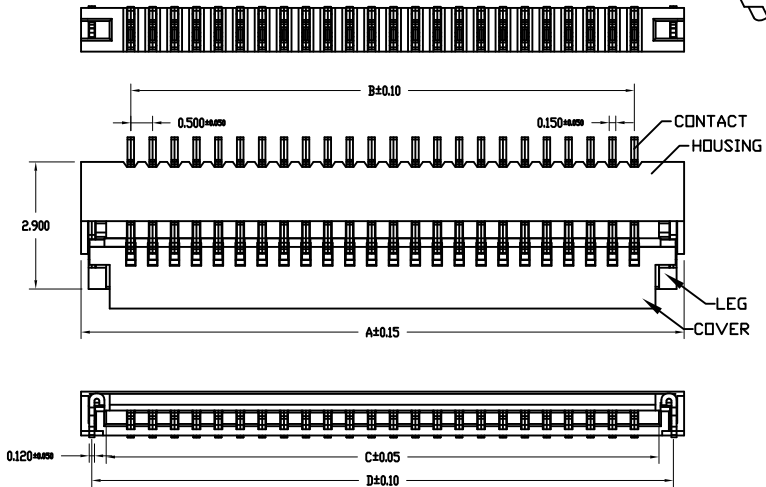

PIN NO.	DIM. A	DIM. B	DIM. C	DIM. D	PIN NO.	DIM. A	DIM. B	DIM. C	DIM. D
04	3.77	1.50	2.60	3.27	23	13.27	11.50	12.10	12.77
05	4.27	2.00	3.10	3.77	24	13.77	11.50	12.60	13.27
06	4.77	2.50	3.60	4.27	25	14.27	12.00	13.10	13.77
07	5.27	3.00	4.10	4.77	26	14.77	12.50	13.60	14.27
08	5.77	3.50	4.60	5.27	27	15.27	13.00	14.10	14.77
09	6.27	4.00	5.10	5.77	28	15.77	13.50	14.60	15.27
10	6.77	4.50	5.60	6.27	29	16.27	14.00	15.10	15.77
11	7.27	5.00	6.10	6.77	30	16.77	14.50	15.60	16.27
12	7.77	5.50	6.60	7.27	31	17.27	15.00	16.10	16.77
13	8.27	6.00	7.10	7.77	32	17.77	15.50	16.60	17.27
14	8.77	6.50	7.60	8.27	33	18.27	16.00	17.10	17.77
15	9.27	7.00	8.10	8.77	34	18.77	16.50	17.60	18.27
16	9.77	7.50	8.60	9.27	35	19.27	17.00	18.10	18.77
17	10.27	8.00	9.10	9.77	36	19.77	17.50	18.60	19.27
18	10.77	8.50	9.60	10.27	37	20.27	18.00	19.10	19.77
19	11.27	9.00	10.10	10.77	38	20.77	18.50	19.60	20.27
20	11.77	9.50	10.60	11.27	39	21.27	19.00	20.10	20.77
21	12.27	10.00	11.10	11.77	40	21.77	19.50	20.60	21.27
22	12.77	10.50	11.60	12.27	n	$n \times 0.5 + 1.77$	$(n-1) \times 0.5$	$n \times 0.5 + 0.6$	$n \times 0.5 + 1.27$

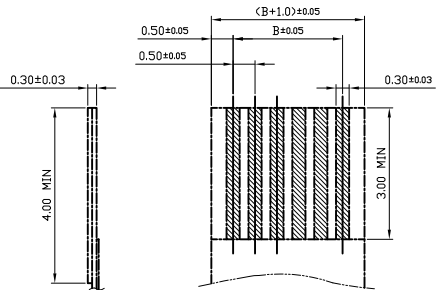

Applicable FPC

FPFA-GXXXXHX-N

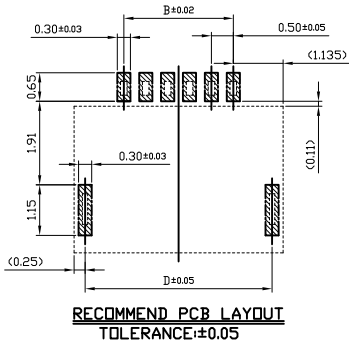
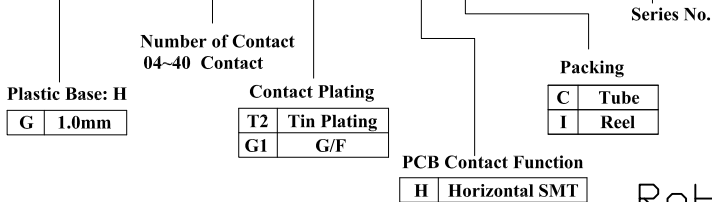

RoHS compliant

竣豪電子股份有限公司
Superior Tech Co., Ltd.

General Tolerance TITLE FPC 0.5 CONNECTOR H1.0 ZIF FOR SMT(BOTTOM CONT)

X. ± 0.5	DRAWN	DATE	NO.
.X ± 0.3	Annie	10-07-19'	D081
.XX ± 0.2	CHECK	DATE	PART NO.
.XXX ± 0.1	Annie	10-07-19'	FPFA-GXXXXHX-N
角度 $\pm 5^\circ$	APPROVED	DATE	CUSTOMER NO.
	Tom	10-07-19'	

REV.	UNIT	SCALE	
A	mm	1:1	